



Welcome to the Energy Future  
Where Energy Technology Drives Better Business

**Wireless Button Press Sensors**

**General Description**

The EDGEVIEW Wireless Button Sensor detects when the button has been pressed triggering a notification from the system.

- Detects when button is pressed

**Principle of Operation**

The EDGEVIEW Wireless Button Sensor sends a signal to the software Online Sensor Monitoring and Notification System when the button is pressed triggering a notification via SMS text or email and tracking the data in the online system and can be reviewed and exported as a data sheet or graph. Notifications can be set up through the online system to alert the user immediately when movement is detected with the ability to only notify within time of day parameters.

**Example Applications**

- Hotel / Motel front desk call button
- Restroom service / clean-up request button
- Service request button
- And many more

**Features of Efficient Power Tech EDGEVIEW Sensors**

- Wireless range of 1,000+ feet through 12-14 walls \*
- Frequency Hopping Spread Spectrum (FHSS)
- Improved interference immunity
- Improved power management for longer battery life \*\* (10+ years on AA batteries)
- Encrypt-RF™ Security (Diffie-Hellman Key Exchange + AES-128 CBC for sensor data messages)
- Onboard data memory / storage (up to 512 readings per sensor)
  - 10 min heartbeats = 3.5 days
  - 2 hour heartbeats = 42 days
- Over-the-air updates (future proof)
- Free software basic online wireless sensor monitoring and notification system to configure sensors, view data and set alerts via SMS text and email.

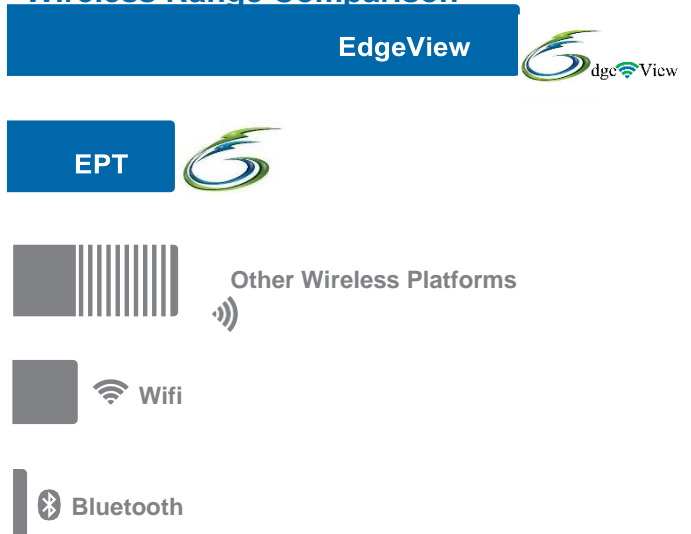

\* Actual range may vary depending on environment.  
\*\* Battery life is determined by sensor reporting frequency and other variables. Other power options are also available.

**Wireless Range Comparison**

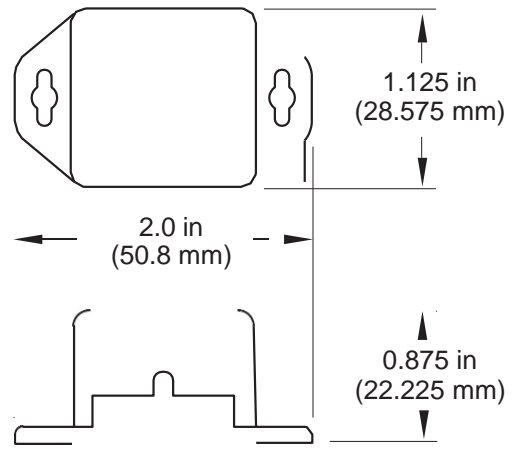



### EdgeView Commercial Coin Cell Wireless Button Press Sensor - Technical Specifications

Supply Voltage	2.0 - 3.8 VDC *
Current Consumption	0.2 $\mu$ A (Sleep Mode) 0.7 $\mu$ A (RTC Sleep) 570 $\mu$ A (MCU Idle) 2.5 mA (MCU Active) 5.5 mA (Radio RX Mode) 22.6 mA (Radio TX Mode)
Operating Temperature Range (Board Circuitry and Coin Cell)	-7°C to +60°C (20°F to +140°F) **
Optimal Battery Temperature Range (Coin Cell)	+10°C to +50°C (+50°F to +122°F)
Button Type	Momentary
Number of Operations	10,000,000
Integrated Memory	Up to 512 sensor messages
Wireless Range	1,000+ ft. non-line-of-sight
Security	Encrypt-RF™ (256-bit key exchange and AES-128 CTR)
Weight	0.7 Ounces
Certifications	  Industry Canada 900 MHz product; FCC ID: ZTL- G2SC1 and IC: 9794A-G2SC1. 868 and 433 MHz product tested and found to comply with: EN 300 220-2 V3.1.1 (2017-02), EN 300 220-2 V3.1.1 (2017-02) and EN 60950.



\* Hardware cannot withstand negative voltage. Please take care when connecting a power device.

\*\* At temperatures above 100°C, it is possible for the board circuitry to lose programmed memory.

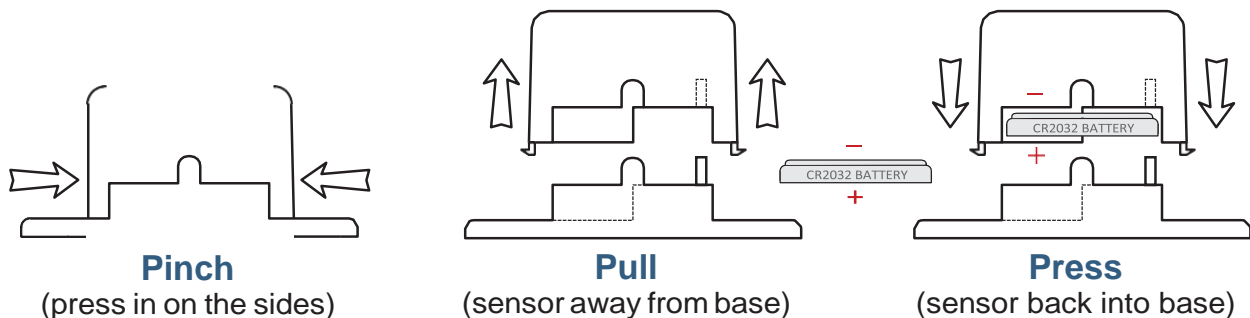
### PinchPower™ Enclosures

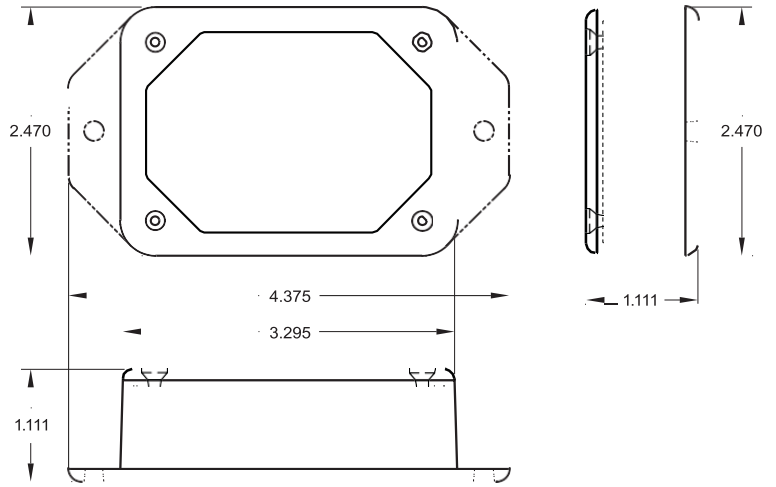



EDGEVIEW Commercial AA Wireless Button Press Sensor - Technical Specifications	
Supply Voltage	2.0 - 3.8 VDC (3.0 - 3.8 VDC Using Power Supply) *
Current Consumption	0.2 $\mu$ A (Sleep Mode) 0.7 $\mu$ A (RTC Sleep) 570 $\mu$ A (MCU Idle) 2.5 mA (MCU Active) 5.5 mA (Radio RX Mode) 22.6 mA (Radio TX Mode)
Operating Temperature Range (Board Circuitry and Batteries)	-18°C to 55°C (0°F to 130°F) using alkaline -40°C to 85°C (-40°F to 185°F) using lithium **
Optimal Battery Temperature Range (AA)	+10°C to +50°C (+50°F to +122°F)
Button Type	Momentary
Number of Operations	10,000,000
Integrated Memory	Up to 512 sensor messages
Wireless Range	1,000+ ft. non-line-of-sight
Security	Encrypt-RF™ (256-bit key exchange and AES-128 CTR)
Weight	3.7 Ounces
Certifications	<div style="display: flex; align-items: center; gap: 20px;"> <div style="text-align: center;">  </div> <div style="text-align: center;">  </div> <div> <p>Industry Canada</p> </div> </div> <p>900 MHz product; FCC ID: ZTL- G2SC1 and IC: 9794A-G2SC1. 868 and 433 MHz product tested and found to comply with: EN 300 220-2 V3.1.1 (2017-02), EN 300 220-2 V3.1.1 (2017-02) and EN 60950.</p>

\* Hardware cannot withstand negative voltage. Please take care when connecting a power device.

\*\* At temperatures above 100°C, it is possible for the board circuitry to lose programmed memory.

## Power Options

The standard version of this sensor is powered by two replaceable 1.5 V AA sized batteries (included with purchase).

This sensor is also available with a line power option. The line powered version of this sensor has a barrel power connector allowing it to be powered by a standard 3.0 - 3.6 V power supply. The line powered version also uses two standard 1.5 V AA batteries as backup for un-interrupted operation in the event of line power outage.

Power options must be selected at time of purchase, as the internal hardware of the sensor must be changed to support the selected power requirements.

## Commercial Grade Sensors:

Efficient Power Tech commercial grade sensors are designed for applications in ordinary environments (normal room temperature, humidity and atmospheric pressure). Do not use these sensors under the following conditions as these factors can deteriorate the product characteristics and cause failures and burn-out.

- Corrosive gas or deoxidizing gas - chlorine gas, hydrogen sulfide gas, ammonia gas, sulfuric acid gas, nitric oxides gas, etc.)
- Volatile or flammable gas
- Dusty conditions
- Under low or high pressure
- Wet or excessively humid locations
- Places with salt water, oils chemical liquids or organic solvents
- Where there are excessively strong vibrations
- Other places where similar hazardous conditions exist

Use these products within the specified temperature range. Higher temperature may cause deterioration of the characteristics or the material quality.



For more information about our products or to place an order, please contact our sales department at 713-783-2367.

Visit us on the web at [www.Efficient Power Tech.com](http://www.Efficient Power Tech.com).

Efficient Power Tech Corporation  
1800 Augusta Dr #232, Houston, TX  
77057  
713-783-2367  
[www.Efficient Power Tech.com](http://www.Efficient Power Tech.com)