



Wireless Flex Sensor

General Description

The Wireless Flex Sensor measures the amount of bend (force) applied to the ribbon sensor.

Features

- Detects and measures bend of ribbon sensor



Free software basic online wireless sensor monitoring and notification system to configure sensors, view data and set alerts via SMS text and email.

Principle of Operation

The wireless flex sensor uses a flexible, stress sensitive ribbon (potentiometer) to accurately measure the amount of bend or force applied to the ribbon. The sensor returns a value of the amount of bend to the software Online Sensor Monitoring and Notification System. The data is stored in the online system and can be reviewed and exported as a data sheet or graph. Notifications can be set up through the online system to alert the user when a set threshold has been met or exceeded.

Example Applications

- Measure mechanical movement
- HVAC air flow monitoring
- Monitor if seats are occupied

And many more...

Efficient Power Tech Sensor Core Specifications

- Wireless Range: 250 - 300 ft. (non-line-of-sight / indoors through walls, ceilings & floors) *
- Communication: RF 900, 920, 868 and 433 MHz
- Power: Replaceable batteries (optimized for long battery life, line-power and solar (Industrial only) options are available.
- Battery Life (at 1 hour heartbeat setting): **
 - Coin Cell > 2-3 years.
 - AA battery > 4-8 years

* Actual range may vary depending on environment.

** Battery life is determined by sensor reporting frequency and other variables.

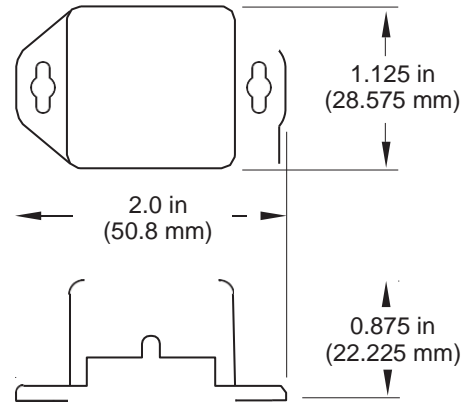

Wireless Flex Sensor (Coin Cell) - Technical Specifications

Supply Voltage	2.0 - 3.6 VDC *
Current Consumption	6 μ A (accelerometer listening for vibrations) 0.7 μ A (sleep mode after measurement) 2 mA (radio idle/off mode) 2 mA (measurement mode) 25 mA (radio RX mode) 35 mA (radio TX mode)
Operating Temperature Range (Board Circuitry and Coin Cell)	-7°C to +60°C (20°F to +140°F) **
Optimal Battery Temperature Range (Coin Cell)	+10°C to +50°C (+50°F to +122°F)
Base Resistance	100 Ω - 500K Ω
Weight	0.7 oz
Wireless Range	250 - 300 ft. (Through walls, ceilings and floors) Range may vary according to environmental variables.
Certifications	900 MHz product; FCC ID: ZTL- RFSC1 and IC: 9794A-RFSC1. 920 MHz product; ARIB STD-T108 R210-103733. 868 and 433 MHz product tested and found to comply with: CISPR 22:2008-09 / EN 55022:2010 - Class B and ETSI EN 300 220-2 V2.4.1 (2012-05).
Industry Canada	

* Hardware cannot withstand negative voltage. Please take care when connecting a power device.

** At temperatures above 100°C, it is possible for the board circuitry to lose programmed memory.

 **Warning: Do not kink or damage the flexible ribbon!**

PinchPower™ Enclosure

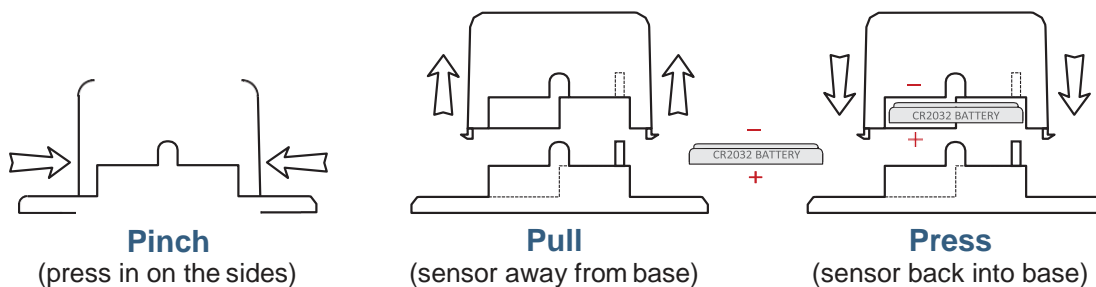

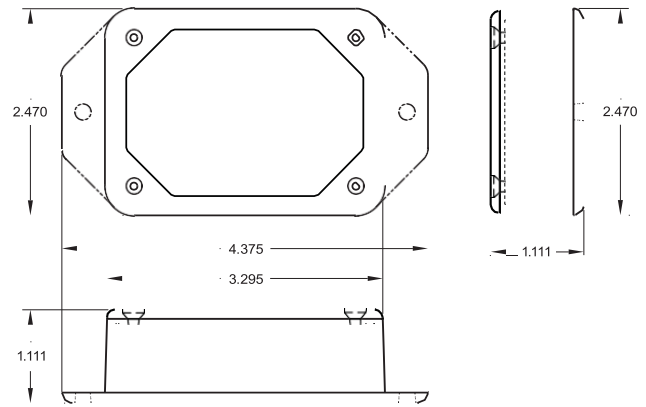

Wireless Flex Sensor (AA) - Technical Specifications	
Supply Voltage	2.0 - 3.6 VDC *
Current Consumption	6 μ A (accelerometer listening for vibrations) 0.7 μ A (sleep mode after measurement) 2 mA (radio idle/off mode) 2 mA (measurement mode) 25 mA (radio RX mode) 35 mA (radio TX mode)
Operating Temperature Range (Board Circuitry and Batteries)	-18°C to 55°C (0°F to 130°F) using alkaline -40°C to 60°C (-40°F to 140°F) using lithium **
Optimal Battery Temperature Range (AA)	+10°C to +50°C (+50°F to +122°F)
Base Resistance	100 Ω - 500K Ω
Weight	3.7 oz.
Wireless Range	250 - 300 ft. (Through walls, ceilings and floors) Range may vary according to environmental variables.
Certifications Industry Canada	900 MHz product; FCC ID: ZTL- RFSC1 and IC: 9794A-RFSC1. 920 MHz product; ARIB STD-T108 R210-103733. 868 and 433 MHz product tested and found to comply with: CISPR 22:2008-09 / EN 55022:2010 - Class B and ETSI EN 300 220-2 V2.4.1 (2012-05).

* Hardware cannot withstand negative voltage. Please take care when connecting a power device.

** At temperatures above 100°C, it is possible for the board circuitry to lose programmed memory.



Warning: Do not kink or damage the flexible ribbon!

Power Options

Two replaceable 1.5V AA sized batteries are included with the standard model. A line-power version with battery backup is also available - allowing it to be powered by a standard 3.0 - 3.6V power supply and use the internal batteries if there is a power interruption.

Power options must be selected at time of purchase as the internal hardware of the sensor must be changed to support the selected power requirements.

Notes:

Commercial Grade Sensors

Efficient Power Tech commercial grade sensors are designed for applications in ordinary environments (normal room temperature, humidity and atmospheric pressure). Do not use these sensors under the following conditions as these factors can deteriorate the product characteristics and cause failures and burn-out.

- Corrosive gas or deoxidizing gas - chlorine gas, hydrogen sulfide gas, ammonia gas, sulfuric acid gas, nitric oxides gas, etc.)
- Volatile or flammable gas
- Dusty conditions
- Under low or high pressure
- Wet or excessively humid locations
- Places with salt water, oils chemical liquids or organic solvents
- Where there are excessively strong vibrations
- Other places where similar hazardous conditions exist

Use these products within the specified temperature range. Higher temperature may cause deterioration of the characteristics or the material quality.



For more information about our products or to place an order, please contact our sales department at 713-783-2367.

Visit us on the web at www.Efficient Power Tech.com.

Efficient Power Tech Corporation
1800 Augusta Dr. #232
Houston, TX, 77057
713-783-2367
www.Efficient Power Tech.com