

Welcome to the Energy Future.  
Where Energy Technology Drives Better Business

## Wireless Water Rope Sensors

### General Description

The EDGEVIEW Wireless Water Rope Sensor detects the presence of water anywhere along the surface of the rope. Sensor comes with 10 feet of water rope. Additional 10 ft. sections are available and can be connected up to 100 feet.

- 10 ft. lead and 10 ft. water detection rope
- Immediately detects water anywhere along rope
- Expandable up to 100 ft. of detection rope

### Principle of Operation

The EDGEVIEW Wireless Water Rope Sensor detects conductive liquids anywhere along the length of the detection rope by using two wires covered with conducting polymer. When water or conductive liquid contacts the rope, the sensor will immediately turn on the RF radio and transmit the data to the wireless gateway and software Online Sensor Monitoring and Notification System, allowing the user to immediately receive an alert by SMS text, email or voice call. The sensor rope dries quickly allowing the sensor to reset for next use. Detection rope can be expanded up to 100 feet by simply clicking additional 10 foot sections of detection rope together. Additional sections of water detection rope are available on the Efficient Power Tech website.

### Example Applications

- Data center and server room water monitoring
- Document retention center monitoring
- Basement water monitoring
- Plumbing leak detection
- Boat bilge monitoring
- Storage monitoring
- And many more...

### Features of Efficient Power Tech EDGEVIEW Sensors

- Wireless range of 1,000+ feet through 12-14 walls \*
- Frequency Hopping Spread Spectrum (FHSS)
- Improved interference immunity
- Improved power management for longer battery life \*\* (10+ years on AA batteries)
- Encrypt-RF™ Security (Diffie-Hellman Key Exchange + AES-128 CBC for sensor data messages)
- Onboard data memory / storage (up to 512 readings per sensor)
  - 10 min heartbeats = 3.5 days
  - 2 hour heartbeats = 42 days
- Over-the-air updates (future proof)
- Free software basic online wireless sensor monitoring and notification system to configure sensors, view data and set alerts via SMS text and email.



\* Actual range may vary depending on environment.

\*\* Battery life is determined by sensor reporting frequency and other variables. Other power options are also available.

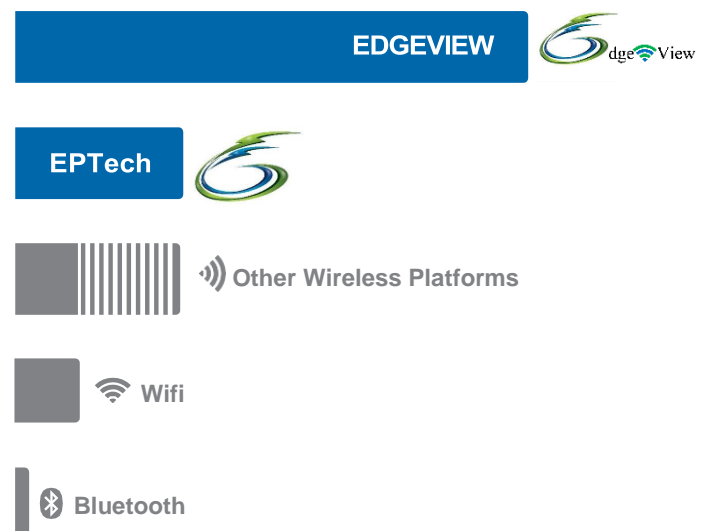
### Wireless Range Comparison

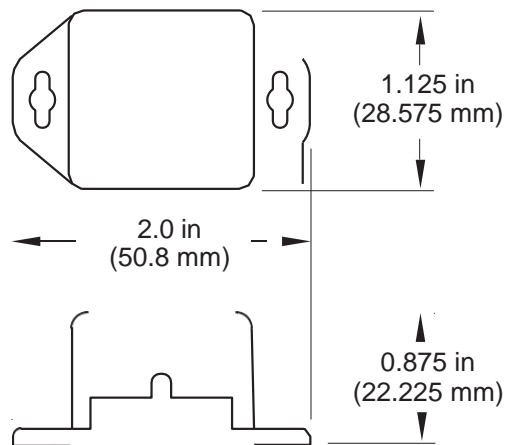



| EDGEVIEW Commercial Coin Cell Wireless Water Rope Sensor - Technical Specifications |   |
|---|---|
| Supply Voltage  | 2.0 - 3.8 VDC *   |
| Current Consumption   | 0.2 $\mu$ A (Sleep Mode)<br>0.7 $\mu$ A (RTC Sleep)<br>570 $\mu$ A (MCU Idle)<br>2.5 mA (MCU Active)<br>5.5 mA (Radio RX Mode)<br>22.6 mA (Radio TX Mode)   |
| Operating Temperature Range (Board Circuitry and Coin Cell)                         | -7°C to +60°C (20°F to +140°F) **   |
| Optimal Battery Temperature Range (Coin Cell)                                       | +10°C to +50°C (+50°F to +122°F)  |
| Water Rope Material   | PE + alloy lead   |
| Water Rope Maximum Exposed Temperature  | 75°C (167°F)  |
| Water Rope Weight   | 30g/meter   |
| Water Rope Pull Force Limit   | 60kg  |
| Water Rope Core Resistance  | 3ohm/100 meters   |
| Water Rope Cable Diameter   | 5.5mm   |
| Water Rope Cable Length   | 10 ft. (120 in.) included (expandable to 100 ft.)   |
| Water Rope Fire Resistance  | Second pressure plenum cable  |
| Integrated Memory   | Up to 512 sensor messages   |
| Wireless Range  | 1,000+ ft. non-line-of-sight  |
| Security  | Encrypt-RF™ (256-bit key exchange and AES-128 CTR)  |
| Sensor Weight   | 0.7 Ounces  |
| Certifications  | <div style="display: flex; align-items: center; gap: 10px;">    <span>Industry Canada</span> </div> 900 MHz product; FCC ID: ZTL- G2SC1 and IC: 9794A-G2SC1. 868 and 433 MHz product tested and found to comply with: EN 300 220-2 V3.1.1 (2017-02), EN 300 220-2 V3.1.1 (2017-02) and EN 60950. |

\* Hardware cannot withstand negative voltage. Please take care when connecting a power device.

\*\* At temperatures above 100°C, it is possible for the board circuitry to lose programmed memory.

### PinchPower™ Enclosures

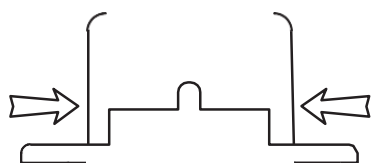

**Pinch**  
(press in on the sides)

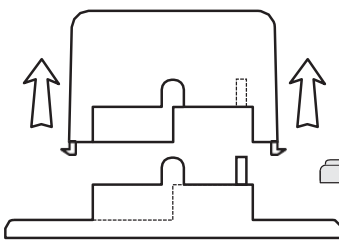

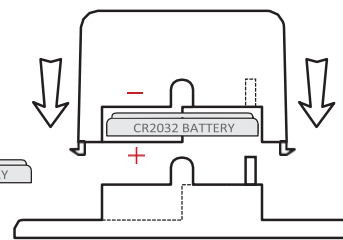

**Pull**  
(sensor away from base)

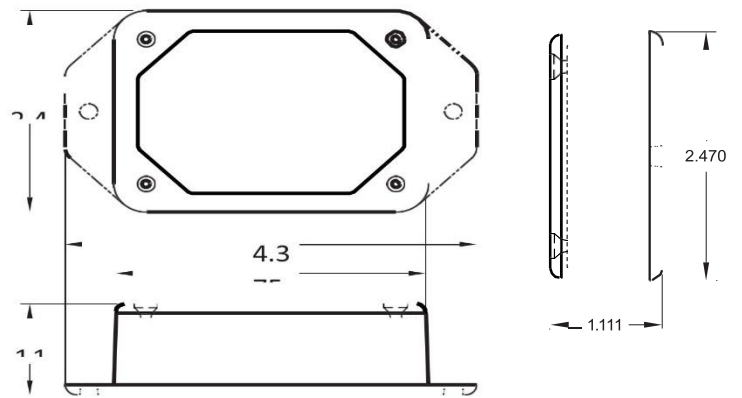

**Press**  
(sensor back into base)



## EDGEVIEW Commercial AA Wireless Water Rope Sensor - Technical Specifications

|   |  |
|---|--|
| Supply Voltage  | 2.0 - 3.8 VDC (3.0 - 3.8 VDC Using Power Supply) *   |
| Current Consumption   | 0.2 $\mu$ A (Sleep Mode)<br>0.7 $\mu$ A (RTC Sleep)<br>570 $\mu$ A (MCU Idle)<br>2.5 mA (MCU Active)<br>5.5 mA (Radio RX Mode)<br>22.6 mA (Radio TX Mode)  |
| Operating Temperature Range (Board Circuitry and Batteries) | -18°C to 55°C (0°F to 130°F) using alkaline<br>-40°C to 85°C (-40°F to 185°F) using lithium **   |
| Optimal Battery Temperature Range (AA)                      | +10°C to +50°C (+50°F to +122°F)   |
| Water Rope Material   | PE + alloy lead  |
| Water Rope Maximum Exposed Temperature                      | 75°C (167°F)   |
| Water Rope Weight   | 30g/meter  |
| Water Rope Pull Force Limit                                 | 60kg   |
| Water Rope Core Resistance                                  | 3ohm/100 meters  |
| Water Rope Cable Diameter                                   | 5.5mm  |
| Water Rope Cable Length                                     | 10 ft. (120 in.) included (expandable to 100 ft.)  |
| Water Rope Fire Resistance                                  | Second pressure plenum cable   |
| Integrated Memory   | Up to 512 sensor messages  |
| Wireless Range  | 1,000+ ft. non-line-of-sight   |
| Security  | Encrypt-RF™ (256-bit key exchange and AES-128 CTR)   |
| Weight  | 3.7 Ounces   |
| Certifications  | <div style="display: flex; align-items: center; gap: 10px;">    <div style="text-align: left;"> <p>Industry<br/>Canada</p> </div> </div> 900 MHz product; FCC ID: ZTL- G2SC1 and IC: 9794A-G2SC1. 868 and 433 MHz product tested and found to comply with: EN 300 220-2 V3.1.1 (2017-02), EN 300 220-2 V3.1.1 (2017-02) and EN 60950. |

\* Hardware cannot withstand negative voltage. Please take care when connecting a power device.

\*\* At temperatures above 100°C, it is possible for the board circuitry to lose programmed memory.

### Power Options



The standard version of this sensor is powered by two replaceable 1.5 V AA sized batteries (included with purchase).

This sensor is also available with a line power option. The line powered version of this sensor has a barrel power connector allowing it to be powered by a standard 3.0 - 3.6 V power supply. The line powered version also uses two standard 1.5 V AA batteries as backup for un-interrupted operation in the event of line power outage.

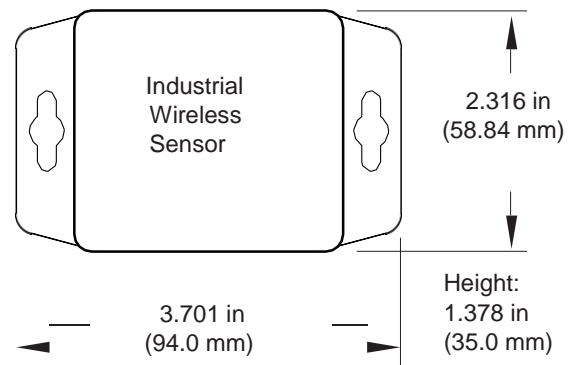
Power options must be selected at time of purchase, as the internal hardware of the sensor must be changed to support the selected power requirements.



### EDGEVIEW Industrial Wireless Water Rope Sensor - Technical Specifications

|   |   |  |
|---|---|--|
| Supply Voltage  | 2.0 - 3.8 VDC (3.0 - 3.8 VDC Using Power Supply) *  |  |
| Current Consumption                                       | 0.2 $\mu$ A (Sleep Mode)<br>0.7 $\mu$ A (RTC Sleep)<br>570 $\mu$ A (MCU Idle)<br>2.5 mA (MCU Active)<br>5.5 mA (Radio RX Mode)<br>22.6 mA (Radio TX Mode)               |  |
| Operating Temperature Range (Board Circuitry and Battery) | -40°C to +85°C (-40°F to +185°F) **   |  |
| Included Battery  | Max Temperature Range:  | -40°C to +85°C (-40°F to +185°F)   |
|   | Capacity:   | 1800 mAh   |
| Optional Solar Feature                                    | Solar Panel:  | 5VDC / 30mA (53mm x 30mm)  |
|   | Charging Temperature Range:   | 0°C to 45°C (32°F to 113°F)  |
|   | Max Temperature Range:  | -20°C to 60°C (-4°F to 140°F)  |
|   | Included Rechargeable Battery:  | 600 mAh / >2000 Charge Cycles (80% of initial capacity)  |
| Water Rope Material                                       | PE + alloy lead   |  |
| Water Rope Maximum Exposed Temperature                    | 75°C (167°F)  |  |
| Water Rope Weight   | 30g/meter   |  |
| Water Rope Pull Force Limit                               | 60kg  |  |
| Water Rope Core Resistance                                | 3ohm/100 meters   |  |
| Water Rope Cable Diameter                                 | 5.5mm   |  |
| Water Rope Cable Length                                   | 10 ft. (120 in.) included (expandable to 100 ft.)   |  |
| Water Rope Fire Resistance                                | Second pressure plenum cable  |  |
| Integrated Memory   | Up to 512 sensor messages   |  |
| Wireless Range  | 1,000+ ft. non-line-of-sight  |  |
| Security  | Encrypt-RF™ (256-bit key exchange and AES-128 CTR)  |  |
| Weight  | 4.7 Ounces  |  |
| Enclosure Rating  | NEMA 1, 2, 4, 4x, 12 and 13 rated, sealed and weather proof   |  |
| UL Rating   | UL Listed to UL508-4x specifications (File E194432)   |  |
| Certifications  |   | 900 MHz product; FCC ID: ZTL- G2SC1 and IC: 9794A-G2SC1. 868 and 433 MHz product tested and found to comply with: EN 300 220-2 V3.1.1 (2017-02), EN 300 220-2 V3.1.1 (2017-02) and EN 60950. |

\* Hardware cannot withstand negative voltage. Please take care when connecting a power device.

\*\* At temperatures above 100°C, it is possible for the board circuitry to lose programmed memory.

## Commercial Grade Sensors:

Efficient Power Tech commercial grade sensors are designed for applications in ordinary environments (normal room temperature, humidity and atmospheric pressure). Do not use these sensors under the following conditions as these factors can deteriorate the product characteristics and cause failures and burn-out.

- Corrosive gas or deoxidizing gas - chlorine gas, hydrogen sulfide gas, ammonia gas, sulfuric acid gas, nitric oxides gas, etc.)
- Volatile or flammable gas
- Dusty conditions
- Under low or high pressure
- Wet or excessively humid locations
- Places with salt water, oils chemical liquids or organic solvents
- Where there are excessively strong vibrations
- Other places where similar hazardous conditions exist

Use these product within the specified temperature range. Higher temperature may cause deterioration of the characteristics or the material quality.

## Industrial Grade Sensors - Type 1, 2, 4, 4X, 12 and 13 NEMA Rated Enclosure:

Efficient Power Tech 's Industrial sensors are enclosed in reliable, weatherproof NEMA rated enclosures. Our NEMA rated enclosures are constructed for both indoor or outdoor use and protect the sensor circuitry against the ingress of solid foreign objects like dust as well as the damaging effects of water (rain, sleet, snow, splashing water, and hose directed water).

- Safe from falling dirt
- Protects against wind blown dust
- Protects against rain, sleet, snow, splashing water, and hose directed water
- Increased level of corrosion resistance
- Will remain undamaged by ice formation on the enclosure



For more information about our products or to place an order, please contact our sales department at 713-783-2367

Visit us on the web at [www.Efficient Power Tech .com](http://www.Efficient Power Tech .com).

Efficient Power Tech Corporation  
1800 Augusta Dr. #232  
Houston, TX, 77057  
713-783-2367  
[www.Efficient Power Tech .com](http://www.Efficient Power Tech .com)